



MODEL: GM1010

### Digital Lux Meter Instruction Manual



Version: GM1010-EN-00

## A. Introduction

Application: widely used in electro-optical sources, research teaching, metallurgy building, industry inspection as well as agriculture researching and illumination control.

### Feature:

- (1)LUX/FC Unit selection function
- (2)Backlight function
- (3)MAX/MIN measurements
- (4)Automatic measurement function
- (5)Data rise and fall time is short
- (6)Low battery indication
- (7)After 5 minute Auto power off

## B. Warning & Cautions

Do not store the product in the environment below:

- a.Humid or dusty environment
- b.High density of salt or sulfur
- c.Environment full of the other chemical gas
- d.High temperature or humidity, or environment in direct sunlight.

### Operation Environmental condition:

- a.Relative humidity<90%RH(not condensation)
- b.Operating temperature 0~40 ℃
- c.Storage temperature 0~50 ℃

## C. Parts description (Figure 1)

1. Sensor connector
2. Metal connecting shaft
3. ON/OFF key
4. Maximum reading hold key (MAX)
5. LCD Display
6. Screw hold for tripod
7. Battery door

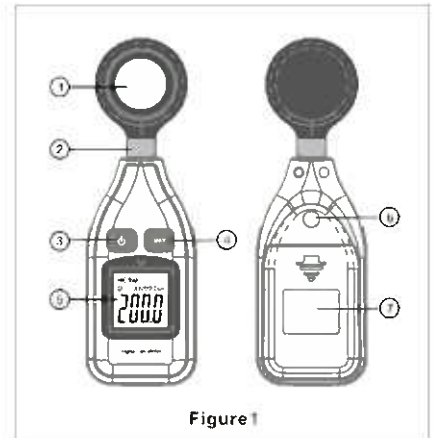

Figure 1

## D. LCD display(Figure 2)

1. Battery icon
2. Maximum reading
3. Minimum reading
4. Reading hold
5. Power off timing icon
6. Difference icon
7. Multiplication
8. Fc/Lux Unit icon
9. Lux reading

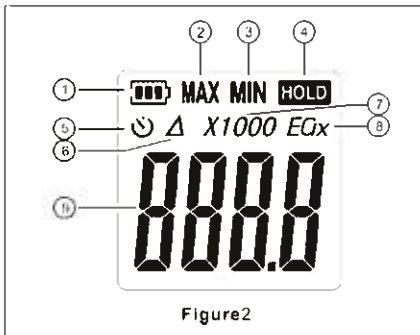

Figure 2

## E. Pre-operations

1. Open the battery door and install 9V battery into the battery compartment.
2. Icon changes from "☹" to "☺", this indicates that battery in the device should be replaced immediately.

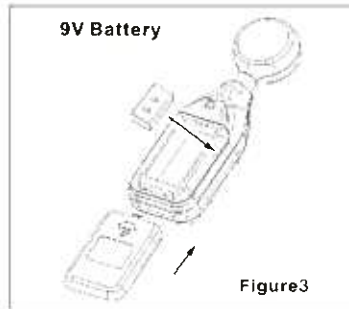

Figure 3

## F. Operation

1. Turn the unit on by pressing the key.
2. Measure mode: press MAX key for 3 seconds to enter into set mode, when the icon flashes, press MAX key to select, then press MAX key again to confirm. And the setting will be saved after turning off or battery replacement.  
Measure mode: circling in the order of  $\Delta$ -HOLD-MIN-MAX
3. Fc/Lux unit switch: press the turn-on key and MAX key at one time to switch the unit.
4. Backlight: In turning on, press the turn on key again to turn off the backlight.
5. Manual Turn off: press the key for 3 seconds after the all display is off then release the key.
6. Auto turn off: the unit will turn off automatically after 5 minutes if there is no any further key operation.

## G. Caution

1. Please take out battery from unit if not in use for any extended period of time.
2. Do not disassemble the unit or attempt internal alterations.
3. Never use alcohol or thinner to clean the unit casing that will especially erode the LCD surface; just clean the unit lightly as needed with little clean water.

## H. Specification

Measuring range	0~200000Lux / 0~18500Fc
Accuracy	$\pm 3\%rdg \pm 0.5\%fs$ (<10,000Lux) $\pm 4\%rdg \pm 10dgts.$ (>10,000Lux)
Digital Updates	2 times / s
Photometric sensor	Silicon diode
Battery life	18 hours(continuous operation)
Operating temperature and humidity	0 ℃~ 40 ℃, 10%RH ~ 90%RH
Storage temperature and humidity	-20 ℃~ 50 ℃, 10%RH ~ 90%RH
Power	9V battery
Unit size	52.5mm*35.5mm*166mm
Auto power off	After 5 minute

**Specific Declarations**  
We reserve the rights of the update and amendment of the product design and the manual which are subject to change without further notification.

